

外置开合式互感器

单相导轨式多功能电力仪表

Rail-type Multifunction Electrical Instrument
with External Split Core Current Transformer

安装使用说明书 V1.3

Use and Installation Manual V1.3

安科瑞电气股份有限公司

Acrel Co., Ltd.

申 明

Announcement

在使用本产品前请仔细阅读本说明，其中涉及的图片、标识、符号等均为安科瑞电气股份有限公司所有。非本公司内部人员未经书面授权不得公开转载全部或者部分内容。

Please read the manual carefully before using the product. The pictures, marks and symbol in the manual belong to Acrel. The manual or part of it shall not be publicly reprinted by people outside the company without written authorization.

本说明内容将不断更新、修正，但难免存在与实物稍有不符或错误的情况。用户请以所购产品实物为准，并可通过 www.ACREL.cn 或销售渠道下载索取最新版本的说明书。

The manual will be continuously updated and corrected but it is inevitable to see a little discrepancy or error if compared with the real products. Please refer to the purchased real product. The latest version of the manual is available on www.ACREL.cn or sales channel upon request.

目录 Content

目录 Content.....	3
1. 概述 Overview.....	1
2. 产品规格 Product Specifications.....	1
3. 产品功能 Product Function.....	2
4. 技术参数 Technical Parameters.....	2
5. 安装 Installation.....	4
5.1 外形及安装尺寸 Overall and Installation Dimensions	4
5.2 开口式互感器尺寸 Open Current Transformer's Dimension	4
5.3 安装方法 Installation Method.....	5
5.4 接线方法 Connection Mode.....	5
6. 编程与使用 Programming and Use.....	6
6.1 面板说明 Panel Description.....	6
6.2 按键功能说明 Button Function Description.....	6
6.3 操作说明 Operation Instructions.....	7
6.4 编程菜单 Programming Menu.....	7
6.4.1 仪表通用编程菜单 General Programming Menu.....	7
6.5 编程示例 Programming Examples.....	8
6.5.1 如何修改电流倍数(CT 变比) How to Change Current Multiplier (CT Transformation Ratio).....	9
6.5.2 编程实例 Programming Cases.....	10
7. 通讯接线 Communication Connection.....	11
7.1 传输方式 Transmitting Method.....	11
7.2 信息帧格式 Information Frame Format.....	11
7.3 功能码简介 Function Code Introduction.....	13
7.3.1 功能码 03H 或 04H: 读寄存器 Function Code 03H or 04H: Reading Register.....	13
7.3.2 功能码 10H: 写寄存器 Function Code 10H: Writing Register.....	13
7.4 通讯应用细节 Communication Application Details.....	14
7.5 通讯地址表(MODBUS-RTU 协议) Communication Address List (MODBUS-RTU Protocol).....	14
7.6 通讯接线实例 Communication Connection Cases.....	16

注意事项：仪表现场安装时必须与配套的开合式互感器一起使用。

Note: The instrument must be installed on the spot together with a complementary split-core current transformer .

1. 概述 Overview

外置开合式互感器的导轨式多功能电力仪表，适用于冶炼、钢铁、电焊、半导体等高能耗行业的节能改造工程，也适用于分布式光伏并网柜的功率监测、电力需求侧管理等应用。具有无需拆一次母线、接线简单方便、施工安全，为用户节约改造成本、提高效率等特点。它集成全部电力参数的测量(如单相或者三相的电流、电压、有功功率、无功功率、视在功率、频率、功率因数)以及电能监测和考核管理。同时它具有多种外围接口功能可供用户选择：带有RS485通讯接口，采用MODBUS-RTU协议可满足通讯联网管理的需要；带开关量输入和继电器输出可实现断路器开关的“遥信”和“遥控”的功能，采用LCD显示界面，通过面板按键来实现参数设置和控制，非常适合于实时电力监控系统。

The rail-type multifunction electrical instrument with external Rogowski coil and split-core current transformer is applicable for the energy-saving reconstruction project in high energy consumption industries including the smelting, iron and steel, welding and semi-conductor industry. It is also suitable for applications such as the power monitoring of grid-connected cabinet for distributed photovoltaic power cabinet and energy demand management. It boasts of no need of bus removal, easy connection and safe construction, saving reconstruction cost and raising efficiency for the user. It integrates the measurements of all electric parameters (including single-phase or three-phase current, voltage, active power, reactive power, apparent power, frequency and power factor) and comprehensive energy monitoring and examination management. Meanwhile, it also has various peripheral interfaces for the user to choose: the RS485 communication interface with MODBUS-RTU protocol can meet the need of online communication management; the interfaces with switch input and relay output can realize the remote signalling and remote control of the circuit breaker switch. It is very suitable for real-time power monitoring system with an LCD display and the panel buttons to realize the setting and control of parameters.

2. 产品规格 Product Specifications

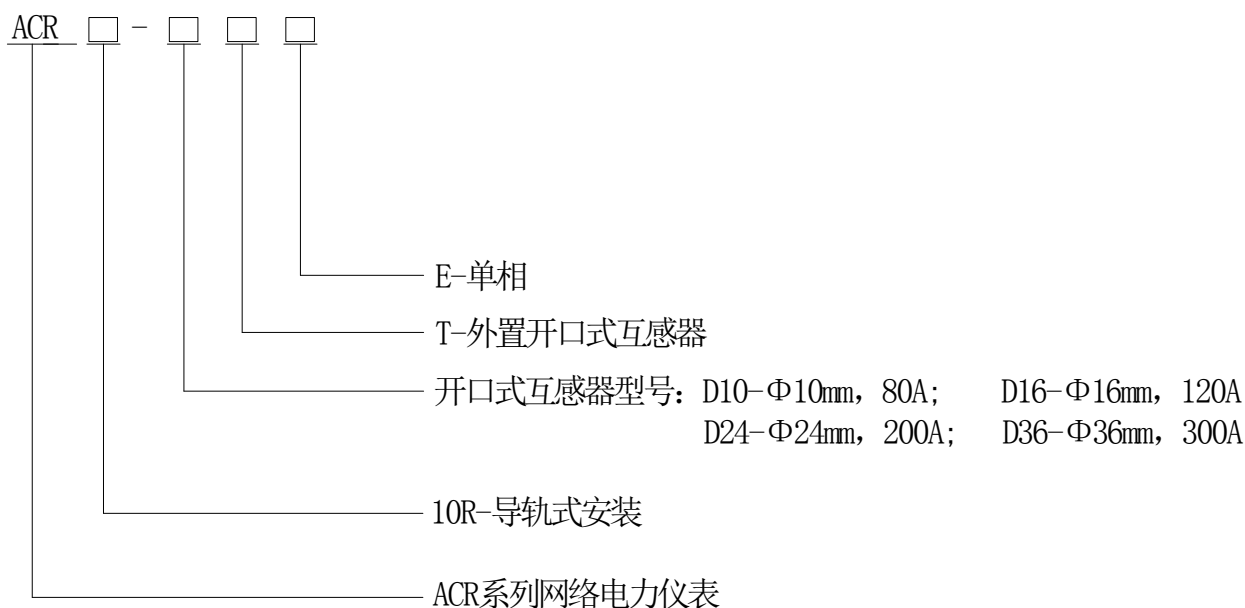

E-单相	E-Single-phase
T-外置开口式互感器	T-External open current transformer
开口式互感器型号	Open current transformer model:
10R-导轨式安装	IOR-Rail-type installation
ACR 系列网络电力仪表	ACR series grid electrical instruments

3. 产品功能 Product Function

型 号 Model		ACR10R-DxxTE
功 能 特 性 Function		
测 量 参 数 Measurement Parameters	单相电流 Single-phase current	■
	单相电压 Single-phase voltage	■
	单相（有功功率、 无功功率、功率因素） Single-phase (active power, reactive power, power factor)	■
	单相 （有功电能、无功电能） Three-phase (active energy, reactive energy)	■

注：1、“■”为标配功能，以上仪表标配 1 路 RS485 通讯；

Note:1.“■”refers to standard function, the standard configuration for above instruments is 1 channel RS485 communication.

4. 技术参数 Technical Parameters

技术参数 Technical parameters		指标 Indicators
输入 Input	网络 Grid	单相 Single-phase,
	频率 Frequency	45~65Hz
	电压 Voltage	额定值：AC 100V、400V Rated voltage: AC 100V, 400V
		过负荷：1.2 倍额定值（连续）； 2 倍额定值持续 1 秒 Overload: 1.2 times the rated voltage(continuous); 2 times the rated voltage lasting for 1 second
	功耗： 小于 0.2VA	

		Power consumption: less then 0.2VA
	电流 Current	额定值: 10A, 20A, 40A, 80A, 120A, 200A 等 (具体见产品规格) Rated current: 10A, 20A, 40A, 80A, 120A, 200A etc. (for details see product specifications)
		过负荷: 1.2 倍额定值 (连续); 10 倍额定值持续 1 秒 Overload: 1.2 times the rated current(continuous);10 times the rated current lasting for 1 second
		功耗: 小于 0.2VA Power consumption: less then 0.2VA
输出 Output	通讯 Communication	RS485 接口、Modbus-RTU RS485 interface, Modbus-RTU
	显示 Display	LCD
测量精度 Measurement precision		电压: 0.2 级, 电流、功率、有功电能: 0.5 级, 频率 0.01Hz、无功电能: 1 级 Voltage: 0.2 level, current, power Active energy: 0.5 level,0.01Hz frequency, Reactive energy: 1 level
电源 Power supply		AC85~265V 或 DC100~350V; 功耗≤10VA AC85~265V or DC100~350V; power consumption ≤10VA
安全性 Safety	工频耐压 Power frequency withstand voltage	电源// //电流输入//电压输入和通讯之间 AC2kV 1min; 电源、电流输入、电压输入两两之间 AC2kV 1min; AC2kV 1 min between power supply // current input//voltage input and communication AC2kV 1 min between each pair of combinations among power supply, urrent input and voltage input.
	绝缘电阻 Insulating resistor	输入、输出端对机壳>100MΩ Input,output terminal to housing >100MΩ
环境 Environment		工作温度: -10℃~+55℃; 储存温度: -20℃~+70℃ Working temperature: -10℃~+55℃;storage temperature: -20℃~+70℃ 相对湿度: 5%~95% 不结露; 海拔高度: ≤2500m Relative humidity:5%~95%, non-condensing; altitude:≤2500m

5. 安装 Installation

5.1 外形及安装尺寸 (单位: mm) Overall and Installation Dimensions (Unit: mm)

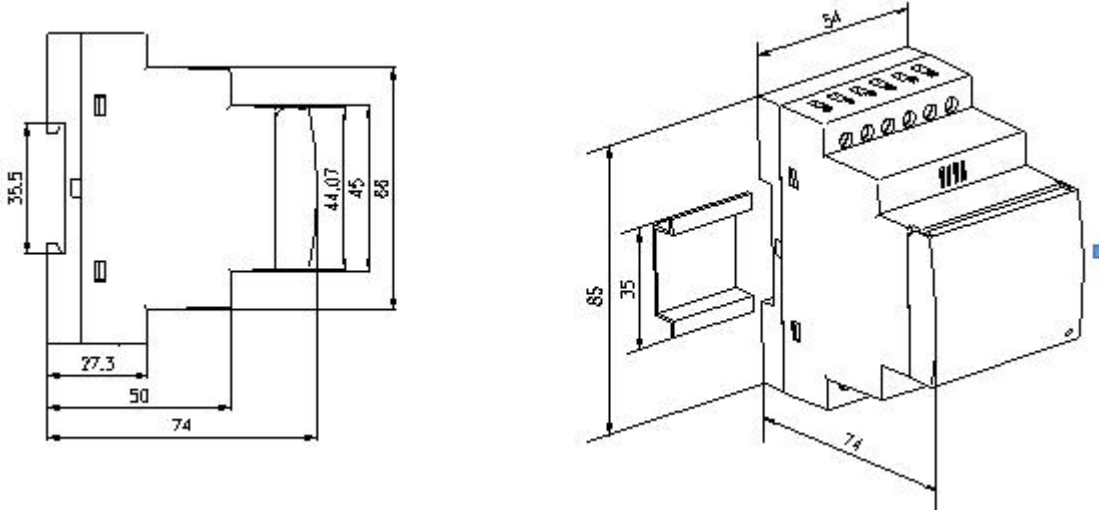

5.2 开口式互感器尺寸 (单位: mm) Open Current Transformer's Dimension (Unit: mm)

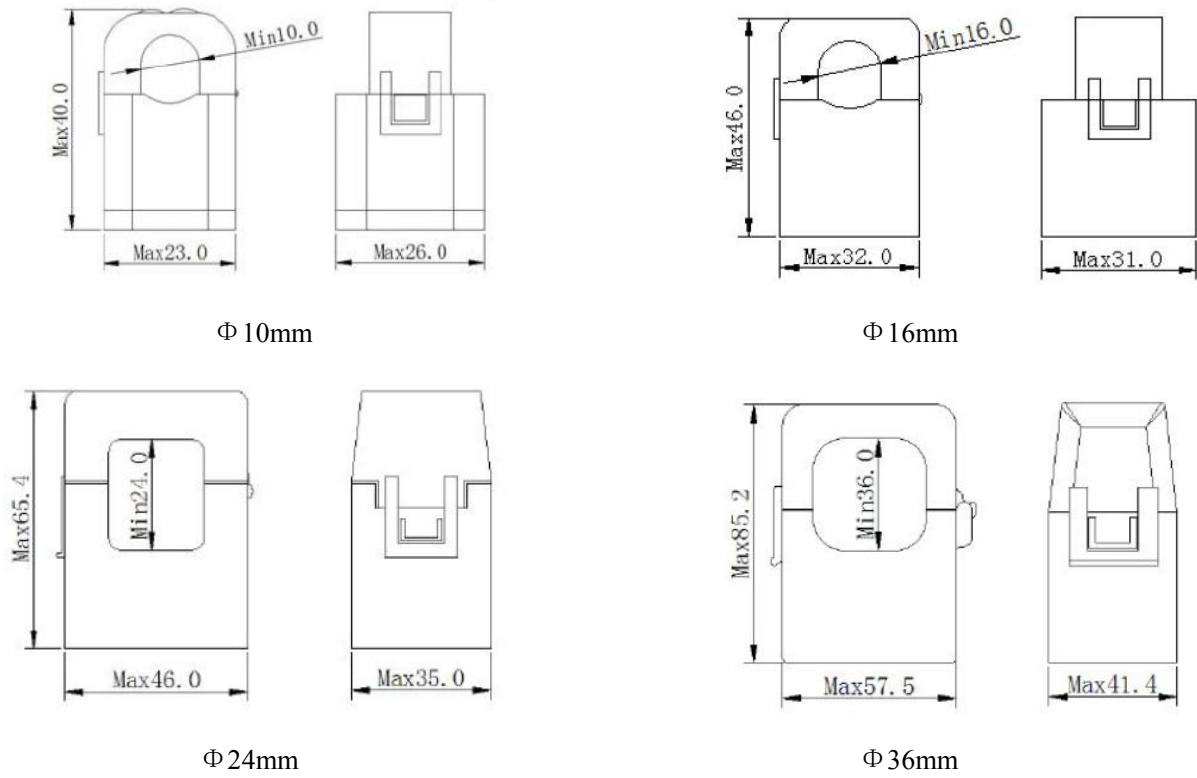

5.3 安装方法 Installation Method

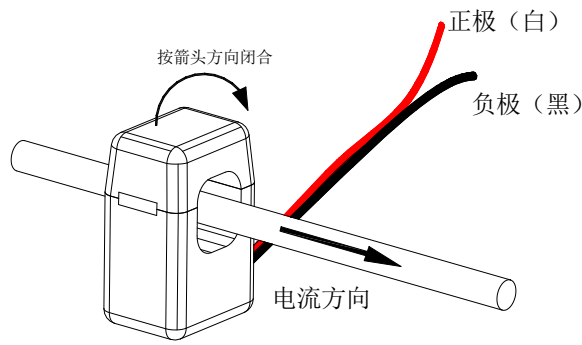

开合式互感器安装方式

Installation Method of the Open Current Transformer Close

按箭头方向闭合	Close according to the arrow direction
正极 (白)	Positive (White)
负极 (黑)	Negative (Black)
电流方向	Current direction

5.4 接线方法 Connection Mode

(注: 如与仪表壳体上接线图不一致, 以仪表壳体上接线图为准)

(Note: The connection diagram on the instrument housing shall prevail in case of any discrepancies with it)

根据不同的设计要求, 推荐在电源、电压输入端子增加保险丝以满足相关电气规范的安全性要求

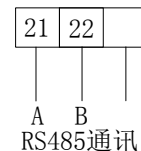
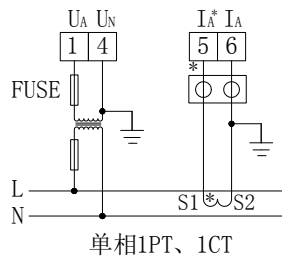
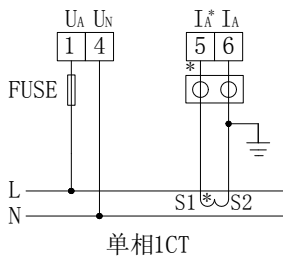

Single-phase 1CT

Single-phase 1PT, 1CT

RS485 communication

注: 接线图中保险丝推荐使用 0.5A 或者 3A;

It is recommended to use 0.5A or 3A for the fuse in the connection diagram;

RS485 通讯端口接线可以选用 RJ45 母头或者普通接线端子, 二者选其一。

RS485 communication terminal connection can use either RJ45 female or normal connector.

6. 编程与使用 Programming and Use

6.1 面板说明 Panel Description

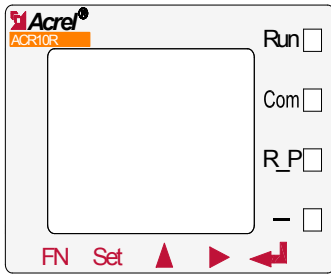

	熄灭	常亮	闪烁
Run (绿色)	仪表未运行	/	仪表正常运行
Com (红色)	仪表未通讯	/	处于通讯状态
R-P (红色)	功率为正	功率为负	/
— (红色)	/	负值指示灯	/

	Off	On	Flashing
Run (Green)	The instrument is not running	/	The instrument is running normally
Com (Red)	The instrument is not communicating	/	The instrument is in communication status.
R-P (Red)	Positive power	Negative power	/
— (Red)	/	Negative value indicator lamp	/

6.2 按键功能说明 Button Function Description

仪表五个按键从左到右依次为 FN 键、SET 键、▲ 键、▶ 键、回车键。

The five buttons of the instrument are FN button, SET button,,Enter button from left to right.

FN 键 FN button	该按键功能暂未开放 The button function is not yet available.
SET 键 SET button	测量模式下，按该键进入编程模式，仪表提示输入密码 PASS，输入正确密码后，可对仪表进行编程设置；编程模式下，用于返回上一级菜单 In the measurement mode, press this button to enter the programming mode. The instrument will indicate entering password. When the correct password is entered, you can set the programming for the instrument; in the programming mode, use it to return to the previous menu
▲ 键	测量模式下，用于切换显示项目； In the measurement mode, it is used to switch display items; 编程模式下，用于切换同级菜单或个位数的减小。 In the programming mode, it is used to switch menus of the same level or reduce the units.
▶ 键	测量模式下，可查看相关参数，具体见显示菜单； In the measurement mode, it can be used to see relevant parameters. For details, see the

	display menu; 编程模式下，用于切换同级菜单或个位数的增加。 In the programming mode, it is used to switch menus of the same level or increase the units.
回车键 Enter button	编程模式下，用于菜单项目的选择确认和参数的修改确认。 In the programming mode, it is used to confirm the items selected form the menu and the modification of parameters.
▲键+回车键 button+Enter button	编程模式下，该组合键用于百位数的减小 In the programming mode, the combination is used to reduce hundreds
▶键+回车键 button+Enter button	编程模式下，该组合键用于百位数的增加 In the programming mode, the combination is used to increase hundreds

6.3 操作说明 Operation Instructions

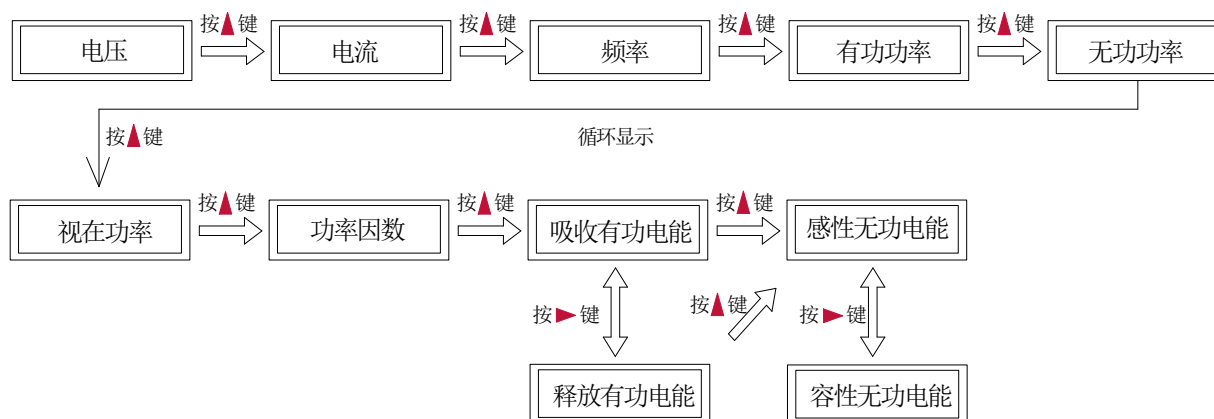

电压	Voltage
电流	Current
频率	Frequency
有功功率	Active power
无功功率	Reactive power
视在功率	Apparent power
功率因素	Power factor
吸收有功电能	Absorb active energy
感性无功电能	Inductive reactive energy
释放有功电能	Release active energy
容性无功电能	Capacitive reactive energy
按 ▲ 键	Press ▲ button

6.4 编程菜单 Programming Menu

6.4.1 仪表通用编程菜单 General Programming Menu

第一级菜单	第二级菜单	第三级菜单	说明
-------	-------	-------	----

1 st level menu	2 nd level menu	3 rd level menu	Description
SYS	DISP		开机显示画面选择, 为零自动翻页 Selection for start-up picture without auto page turning
	Code	0-9999	密码设置 (初始密码 0001) Password setting (initial password 0001)
	ClrE		电能清零, 清除成功显示 OK OK is displayed when energy cleared off
	Err		异常次数统计 Abnormal data statistics
In	Line	1P2L,3P3L、3P4L	接线方式(单相、三相三线、三相四线) Connection mode(single-phase, three-phase three-wire, three-phase four-wire)
	InU	100、400	输入电压范围 Input voltage range
	InI	10, 20, 40, 80, 120, 200, 300 等 (详细见产品规格) 10,20,40,80,120,200,300etc.(For details, please see product specifications)	输入电流范围 (用户不可操作) Input current scope (not for user operation)
	InPt	0-9999	电压倍数 Voltage multiplier
	InEt	0-9999	电流倍数 Current multiplier
	bus	Addr	1-247
baud		4800、9600、19200、38400	通讯波特率 Communication baud rate
mode		None/2bit/odd/even	通信模式 Communication mode (无校验、2 位停止位、奇校验、偶校验) (no parity, 2 stop bit, odd parity, even parity)

6.5 编程示例 Programming Examples

编程示例以流程图的形式介绍改变编程菜单中的某些选项, 如电流倍数、变送设置等。

This section introduces some option change in the programming menu in the form of work flow chart, such as the current multiplier, transformer setting.

注: 在设置或选择完成后, 需按回车键进行确认, 确认完成后连续点按 SET 键直到出现 SAVE/YES 页面, 此时必须按回车键确认, 否则设置无效。

Note: When the setting or selection is done, the Enter button must be pressed to confirm it. After the confirmation is complete, continuously press the SET button until the SAVE/YES page appears. At this time, the Enter button must be pressed at this time or the setting will not be valid.

6.5.1 如何修改电流倍数(CT 变比) How to Change Current Multiplier (CT Transformation Ratio)

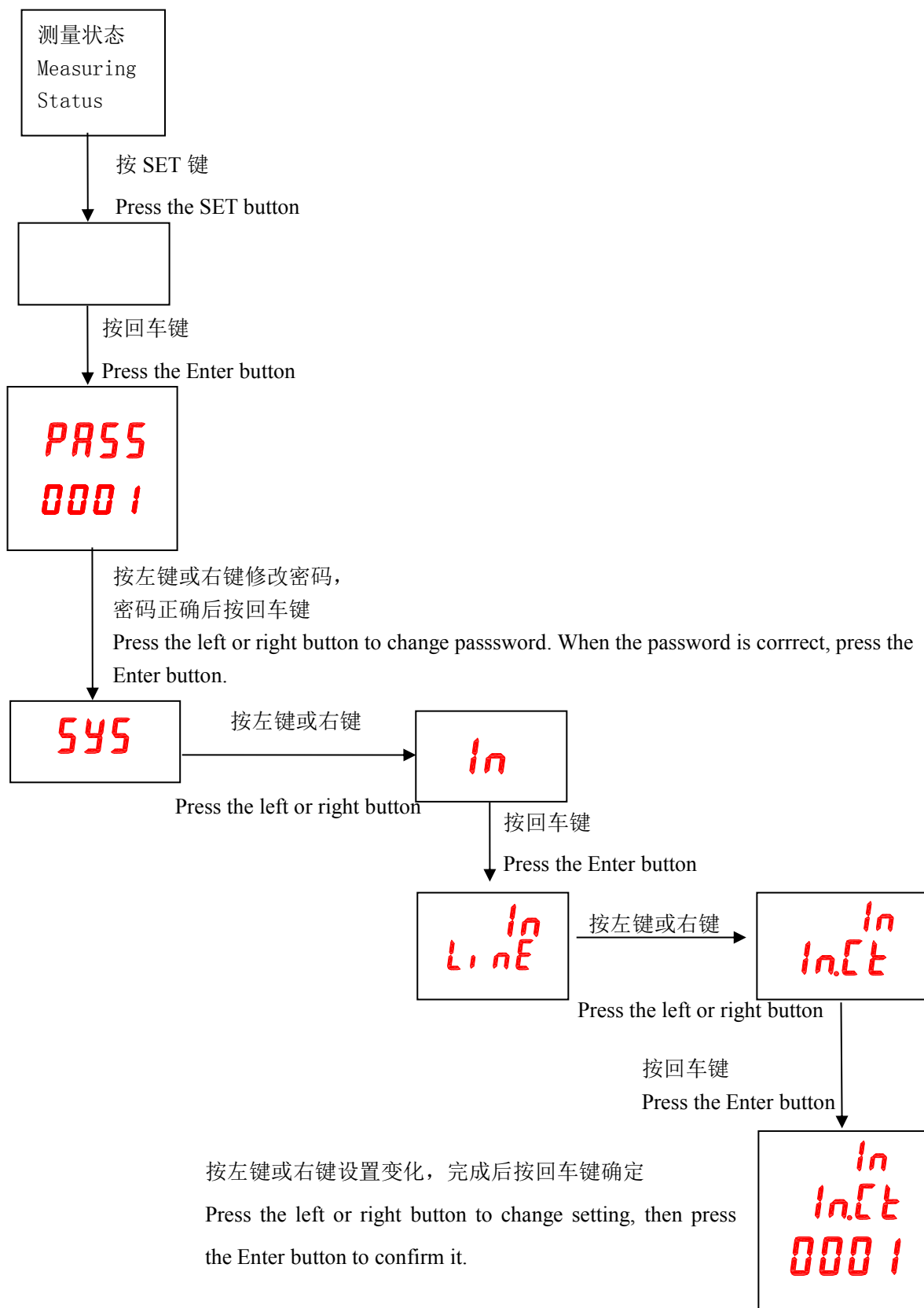

7. 通讯接线 Communication Connection

该仪表提供异步半双工 RS485 通讯接口，采用 MODBUS-RTU 协议，各种数据信息均可在通讯线路上传送。理论上在一条线路上可以同时连接多达 128 个仪表，每个仪表均可设定其通讯地址 (Addr)，通讯速率 (baud) 也可通过设置选择。

The instrument provides asynchronous half-duplex RS485 communication interface which adopts MODBUS-RTU protocol so all kinds of data can be transmitted on the communication line. Theoretically, one communication line can be connected with up to 128 instruments, each of which can set a communication address (Addr) and communication rate (baud) via setting.

通讯连接建议使用三芯屏蔽线分别接 A、B、COM2，屏蔽层接大地，COM2 禁止接大地，布线时应使通讯线远离强电电缆或其他强电场环境。

For the communication connection, we recommend to use the three-core shielding wire. The core wires are connected to A, B, COM2 respectively and the shielding layer is connected to the ground. COM2 is forbidden to have ground connection. When laying the wires, the communication line shall be kept away from the strong current cable or other strong electric field.

建议最末端仪表的 A、B 之间加匹配电阻，阻值范围为 $120\ \Omega \sim 10k\ \Omega$ 。

It is recommended to add a matching resistor between A and B of the end instruments. The resistance range is $120\ \Omega \sim 10k\ \Omega$.

具体接线实例见 7.6 所示。

See 7.6 for specific connection case.

7.1 传输方式 Transmitting Method

信息传输为异步方式，并以字节为单位，在主机和从机之间传递的通讯信息是 10 位字格式，包含 1 个起始位、8 个数据位（最小的有效位先发送）、无奇偶校验位、1 个停止位，如设置为奇偶校验位或 2 位停止位，则为 11 位字格式。

The information transmission is asynchronous and in bytes. The communication message transmitted from the master to the slave is in 10-bit format including 1 start bit, 8 data bit (LSB first delivered), no parity bit, one stop bit. If parity bit or 2 stop bit is set, the format is 11-bit.

7.2 信息帧格式 Information Frame Format

地址码 Address code	功能码 Function code	数据区 Data zone	CRC 校验码 CRC check code
1 字节 1 byte	1 字节 1 byte	n 字节 n byte(s)	2 字节 2 bytes

地址码：地址码在帧的开始部分，由一个字节（8 位二进制码）组成，十进制为 0~255，在 PZ 仪表中只使用 1~247，其它地址保留。这些位标明了用户指定的终端设备的地址，该设备将接收来自与之相连的主机数据。每个终端设备的地址必须是唯一的，仅仅被寻址到的终端会响应包含了该地址的查询。当终端发送回一个响应，响应中的从机地址数据便告诉了主机哪台终端正与之进行通信。

Address code: the address code is in the beginning of the frame, which is composed of a byte (8 bit binary code) representing 0~255 in decimal system. The PZ instrument only uses 1~247 and keeps other addresses. The bits indicate the address of the terminal device designated by the user. The device will receive the data from the linked master.

The address of every terminal device must be unique. Only the end addressed will correspond to the query containing its address. When the terminal sends back a response, the responding slave address will tell the master which terminal is communicating with it.

功能码：功能码告诉了被寻址到的终端执行何种功能。下表列出了该系列仪表用到的功能码，以及它们的意义和功能。

Function code: the function code tells the addressed terminal to carry out which functions. The table below lists up the function codes used by this instrument as well as their meanings and functions.

功能 Function	定义 Definition	操作 Operation
03H/04H	读数据寄存器 Data reading register	获得一个或多个寄存器的当前二进制值 Obtaining the current binary value of one or more registers.
10H	预置多寄存器 Preset multi-register	设定二进制值到一系列多寄存器中 Set the binary value into a series of multi-register

数据区：数据区包含了终端执行特定功能所需要的数据或者终端响应查询时采集到的数据。这些数据的内容可能是数值、参考地址或者设置值。例如：功能码告诉终端读取一个寄存器，数据区则需要指明从哪个寄存器开始及读取多少个数据，内嵌的地址和数据依照类型和从机之间的不同内容而有所不同。

Data zone: the data zone contains the data needed for carrying out certain functions or collected when the terminal responds to the query. The content of the data may be number, reference address or set value. For example: if the function code tells the terminal to read a register, the data zone needs to specify which register to start with and how much data to be read. The embedded address and data will vary with types and different content of the slaves.

CRC 校验码：错误校验（CRC）域占用两个字节，包含了一个 16 位的二进制值。CRC 值由传输设备计算出来，然后附加到数据帧上，接收设备在接收数据时重新计算 CRC 值，然后与接收到的 CRC 域中的值进行比较，如果这两个值不相等，就发生了错误。

CRC check code: CRC field occupies two bytes including one 16-bit binary value. The CRC value is calculated by the transmitting device then added to the data frame. The receiving device will recalculate the CRC value upon receiving the data then compare it with the received value in the CRC field. If the two values are not identical, there is an error.

生成一个 CRC 的流程为：The procedure to generate a CRC

- a、预置一个 16 位寄存器为 0FFFFH（全 1），称之为 CRC 寄存器。

Preset a 16-bit register as 0FFFFH (full 1), which is called CRC register.

- b、把数据帧中的第一个字节的 8 位与 CRC 寄存器中的低字节进行异或运算，结果存回 CRC 寄存器。

Make XOR calculation with 8 bit of the first byte in the data frame and the lower byte in the CRC register and store the result into the CRC register.

- c、将 CRC 寄存器向右移一位，最高位填以 0，最低位移出并检测。

Shift the CRC register right a bit and fill the MSB with 0 and take out the LSB for checking.

- d、如果最低位为 0，重复第三步（下一次移位）；如果最低位为 1，将 CRC 寄存器与一个预设的固定值(0A001H)进行异或运算。

If the LSB is 0, repeat step 3 (one more shift); if the LSB is 1, make XOR calculation with CRC register and preset fixed value (0A001H).

e、重复第三步和第四步直到 8 次移位。这样处理完了一个完整的八位。

Repeat step three and step four until the 8th shift. The entire 8 bit processing is complete in this way.

f、重复第 2 步到第 5 步来处理下一个八位，直到所有的字节处理结束。

Repeat step two to five to process the next 8 bits until all bytes are processed.

g、最终 CRC 寄存器的值就是 CRC 的值。

Finally, the CRC register value becomes the CRC value.

此外还有一种利用预设的表格计算 CRC 的方法，它的主要特点是计算速度快，但是表格需要较大的存储空间，该方法此处不再赘述，请参阅相关资料

Besides, there is also a way to calculate CRC using the preset table. It is characterized by rapid calculation speed. However, the table needs relatively large storage room. We will not introduce it here, please refer to relevant materials.

7.3 功能码简介 Function Code Introduction

7.3.1 功能码 03H 或 04H：读寄存器 Function Code 03H or 04H: Reading Register

此功能允许用户获得设备采集与记录的数据及系统参数。主机一次请求的数据个数没有限制，但不能超出定义的范围。

The function allows the user to obtain the data collected and recorded by the device and system parameters. The data number requested by the master computer for one time has no limitation but cannot exceed the defined address range.

下面的例子是从 01 号从机读 3 个采集到的基本数据（数据帧中每个地址占用 2 个字节）UAB、UBC、UCA，其中 UAB 的地址为 0028H，UBC 的地址为 0029H，UCA 的地址为 002AH。

The following examples are 3 basic data read from 01 slave computer (every address in the data frame takes up 2 bytes):UAB, UBC, UCA. Among them, UAB's address is 0028H, UBC's address is 0029H and UCA's address is 002AH.

主机发送 Sent by master		发送信息 Sent message	从机返回 Feedback by slave		返回信息 Feedback message
地址码 Address code		01H	地址码 Address code		01H
功能码 Function code		03H	功能码 Function code		03H
起始地址 Start address	高字节 UB	00H	字节数 Bytes		06H
	低字节 LB	28H	寄存器数据 Register data	高字节 UB	不定值 Undefined
寄存器数量 Number of registers	高字节 UB	00H		低字节 LB	不定值 Undefined
	低字节 LB	03H	寄存器数据 Register data	高字节 UB	不定值 Undefined
CRC 校验码 CRC check code	低字节 LB	85H		低字节 LB	不定值 Undefined
	高字节 UB	C3H	寄存器数据 Register data	高字节 UB	不定值 Undefined
				低字节 LB	不定值 Undefined
			CRC 效验码 Register data	低字节 LB	不定值 Undefined
				高字节 UB	不定值 Undefined

7.3.2 功能码 10H：写寄存器 Function Code 10H: Writing Register

功能码 10H 允许用户改变多个寄存器的内容，该仪表中系统参数、开关量输出状态等可用此功能号写入。主机一次最多可以写入 16 个 (32 字节) 数据。

The function code 10H allows the user to change the contents of multiple registers. The function code can be used

to write the system parameters and switch output status. The master computer can write a maximum of 16 pieces of data (32 bytes) at once.

下面的例子是预置地址为01的仪表输出开关量Do1。开关量输入/输出状态指示寄存器地址为0022H，第9-12位对应DI1-DI4，第13-14位分别对应D01-D02。

The following example shows that when the preset address is 01, the switch output is Do1. The switch input/output status indication register's address is 0022H. The 9-12 bit corresponds to DI1-DI4, the 13-14 bit corresponds to D01-D02 respectively.

主机发送 Sent by master		发送信息 Sent message		从机返回 Feedback by slave		返回信息 Feedback message	
地址码 Address code		01H		地址码 Address code		01H	
功能码 Function code		10H		功能码 Function code		10H	
起始地址 Start address	高字节 UB	00H		起始地址 Start address	高字节 UB	00H	
	低字节 LB	22H			低字节 LB	22H	
寄存器数量 Register number	高字节 UB	00H		寄存器数量 Register number	高字节 UB	00H	
	低字节 LB	01H			低字节 LB	01H	
字节数 Byte number		02H		CRC 校验码		低字节 LB	A1H
0022H 待写入数据		高字节 UB	10H	CRC 校验码		高字节 UB	C3H
0022H data to be written		低字节 LB	00H				
CRC 校验码		低字节 LB	ADH				
CRC check code		高字节 UB	12H				

7.4 通讯应用细节 Communication Application Details

仪表在设计时对通讯地址表进行了统一规划，用户根据下面的介绍可以方便地实现遥测、遥信、遥控等功能。

The instrument design has a uniform planning for the communication address list. The user can easily realize the functions of remote measurement, remote signalling and remote control according to the following introduction.

7.5 通讯地址表(MODBUS-RTU 协议) Communication Address List (MODBUS-RTU Protocol)

(1Float=2Word, 1Word=8Byte)

地址 Address	参数 Parameters	读写属性 R/W attribute	数值范围 Number range	数据类型 Data type	备注 Remarks
0000H	保护密码 Protective password	R/W	0001-9999	word	
0001H 高字节 0001H UB	通讯地址 Communication address	R/W	0001-0247	word	
0001H 低字节 0001H LB	通讯波特率 Baud rate	R/W	0-3: 38400、19200、9600、4800bps		
0002H	保留 Reserved	R	厂家参数，禁止用户写命令 Factory parameters. Users are not allowed to write an order.	word	
0003H	PT 变比	R/W	1-9999	word	

	PT transformation ratio				
0004H	CT 变比 CT transformation ratio	R/W	1-9999	word	
0005H~0021H	保留 Reserved	R	厂家参数，禁止用户写命令 Factory parameters. Users are not allowed to write an order.	word	
0061H	U	R	0-65535	word	保留 1 位小数 1 bit decimal is reserved
0062H~0063H	保留 Reserved	R		word	
0064H	I	R	0-65535	word	保留 2 位小数 2 bit decimal is reserved
0065H~0066H	保留 Reserved	R		word	
0067H	P	R	-32760—+32760	word	保留 3 位小数， 单位为 KW 3 bit decimal is reserved, KW
0068H~006AH	保留 Reserved	R		word	
006BH	Q	R	-32760—+32760	word	保留 3 位小数， 单位为 KVar 3 bit decimal is reserved, KVar
006CH~006EH	保留 Reserved	R		word	
006FH	S	R	0—65535	word	保留 3 位小数， 单位为 KVA 3 bit decimal is reserved, KVA
0070H~0072H	保留 Reserved	R		word	
0073H	PF	R	0-100	word	保留 2 位小数 2 bit decimal is reserved
0074H~0076H	保留 Reserved	R		word	
0077H	F	R	4500-6500		保留 2 位小数 2 bit decimal is reserved
0078H~007AH	保留 Reserved				
以下为电能地址表 Energy adress list below					
0047H~0048H	吸收有功电能 Absorbing active energy	R	0-9999999999	Float	一次侧电能 Primary energy

0049H~004AH	释放有功电能 Releasing active energy	R	0-9999999999	Float	一次侧电能 Primary energy
004BH~004CH	感性无功电能 Reactive energy	R	0-9999999999	Float	一次侧电能 Primary energy
004DH~004EH	容性无功电能 Capacitive reactive energy	R	0-9999999999	Float	一次侧电能 Primary energy

7.6 通讯接线实例 Communication Connection Cases

关于通讯的接线实例如下图所示：The communication connection cases are shown as below:

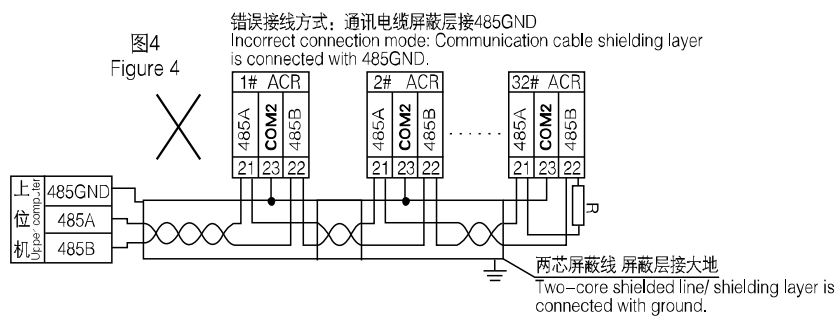
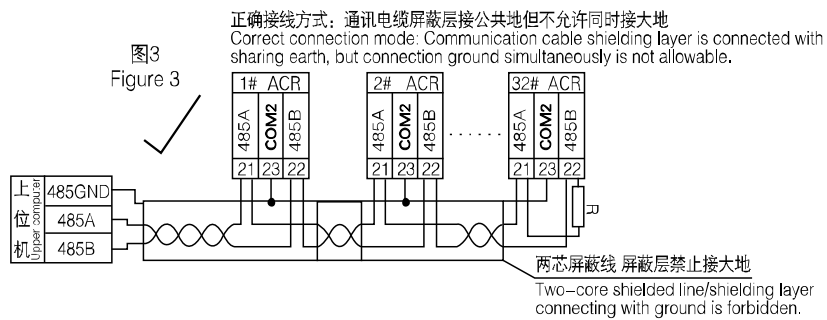
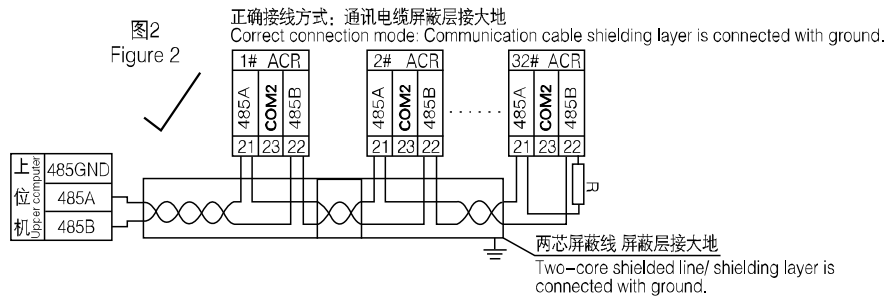
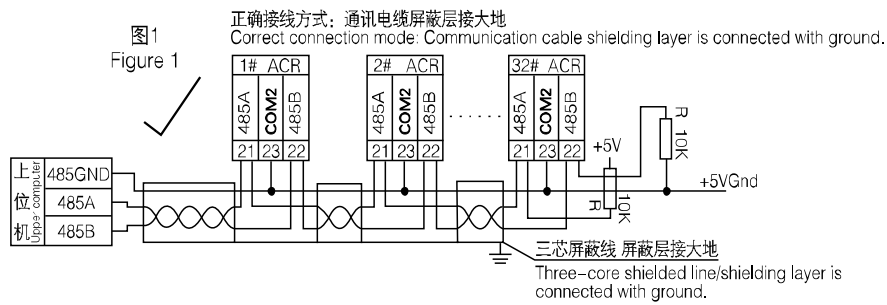

总部：安科瑞电气股份有限公司

Headquarter: Acrel Co., LTD.

地址：上海市嘉定区育绿路 253 号

Address: No.253 Yulv Road Jiading District, Shanghai , China

电话：0086-21-69158338 0086-21-69156052 0086-21-59156392 0086-21-69156971

TEL.: 0086-21-69158338 0086-21-69156052 0086-21-59156392 0086-21-69156971

传真：0086-21-69158303

Fax: 0086-21-69158303

网址：www.acrel-electric.com

Web-site: www.acrel-electric.com

邮箱：ACREL008@vip.163.com

Email : ACREL008@vip.163.com

邮编：201801

Postcode: 201801

生产基地：江苏安科瑞电器制造有限公司

Manufacturer: Jiangsu Acrel Electrical Manufacturing Co., LTD.

地址：江苏省江阴市南闸街道东盟工业园区东盟路 5 号

Address : No.5 Dongmeng Road,Dongmeng industrial Park, Nanzha Street,Jiangyin City,Jiangsu

Province,China

电话(传真)：0086-510-86179970

TEL./Fax: 0086-510-86179970

网址：www.jsacrel.com

Web-site: www.jsacrel.com

邮箱：JY-ACREL001@vip.163.com

Email:JY-ACREL001@vip.163.com

邮编：214405

Postcode : 214405