

022

[^]Acrel[@]
安科瑞电气

B A 系列交流电流传感器

BA Series AC current transformer

安装使用说明书 V1.1

Installation and operation instruction V1.1

总部：上海安科瑞电气股份有限公司
地址：上海市嘉定区马东工业园育绿路 253 号
电话：021-69158300 69158301 69158302 传真：
021-69158303
服务热线：800-820-6632
网址：www.acrel.cn
邮箱：ACREL001@vip.163.com
邮编：201801

生产基地：江苏安科瑞电器制造有限公司
地址：江阴市南闸镇东盟工业园区东盟路 5 号
电话：(86) 0510-86179966 86179967 86179968 传
真：(86)0510-86179975
邮编：214405
邮箱：JY-ACREL001 @vip. 163.com

江苏安科瑞电器制造有限公司
Jiangsu Acrel Appliance Manufacture Co., Ltd.

申明

DECLARATION

版权所有，未经本公司之书面许可，此手册中任何段落，章节内容均不得被 摘抄、拷贝或以任何形式复制、传播，否则一切后果由违者自负。
本公司保留一切法律权利。

No part of this publication may be reproduced, stored in a retrieval system, or transmitted in any form by any means, electronic, mechanical photocopying, recording, or otherwise without prior permission of Acrel. All rights reserved.

本公司保留对本手册所描述之产品规格进行修改的权利，恕不另行通知。 订货前，请垂询当地代理商以获悉本产品的最新规格。

This company reserve power of revision of product specification described in this manual, without notice. Before ordering, please consult local agent for the latest specification of product.

目录

CONTENTS

1 产品概述 General-----	1
2 型号说明 Explanation of type-----	1
3 通用技术条件 General specification-----	2
4 产品规格 Product specification-----	2
4.1 BA05-AI 交流电流传感器 AC current sensor-----	2
4.2 BA10-AI 交流电流传感器 AC current sensor-----	3
4.3 BA 20-AI 交流电流传感器 AC current sensor-----	3
4.4 BA50-AI 交流电流传感器 AC current sensor-----	4
5 外形及安装 Outline and Installation-----	4
5.1 BA05-AI 交流电流传感器 AC current sensor-----	4
5.2 BA10-AI 交流电流传感器 AC current sensor-----	5
5.3 BA20-AI 交流电流传感器 AC current sensor-----	5
5.4 BA50-AI 交流电流传感器 AC current sensor-----	5
5.5 应用实例 Applied example-----	6
6 BA50L 交流剩余电流传感器 AC residual current sensor-----	7
6.1 BA50L-AI/I(V)-T 交流剩余电流传感器(真有效值测量) AC residual current sensor (True RMS measuring)-----	7
6.2 BA50L-AI 交流剩余电流传感器外形及安装 Outline and installation of AC residual current sensor-----	7
6.3 应用实例 Applied example-----	8
6.3.1 单相回路 Single phase circuit-----	8
6.3.2 三相三线回路 Three - phase three-wire circuit-----	9
6.3.3 三相四线回路 Three - phase four-wire circuit-----	10
7 接线方式 Connection mode-----	11
8 订货范例 Ordering example-----	12

BA 系列产品应用电磁感应原理，对电网中的交流电流进行实时测量，采用精密恒流和线性补偿技术，将其隔离变换为标准的直流信号输出。DCN4V 或 DC12V 安全电压供电，具有过载能力强、高精度、高隔离、高安全性、低功耗等特点，可广泛用于工业自动化领域。BA50L 交流剩余电流传感器主要检测用电系统的漏电流，能随时掌握电气线路和设备的情况，防止因漏电而发生的火灾等事故。

BA Series products use electromagnet induction principle to real time measure AC current in grid, adopt precise constant current and linear compensation technology convert its isolation into standard DC signal output. With features of safe voltage of 24V or 12 V, high overload capacity, high precision, high isolation, high safety, low power consumption etc., so, it is widely used in industrial automation field. BA50L as a AC residual current transformer is mainly used for detecting leakage current in power system, real time understand situation of electrical line and equipment to prevent leakage result in fire or other accident,

， 如旧 W1 Explanation of type

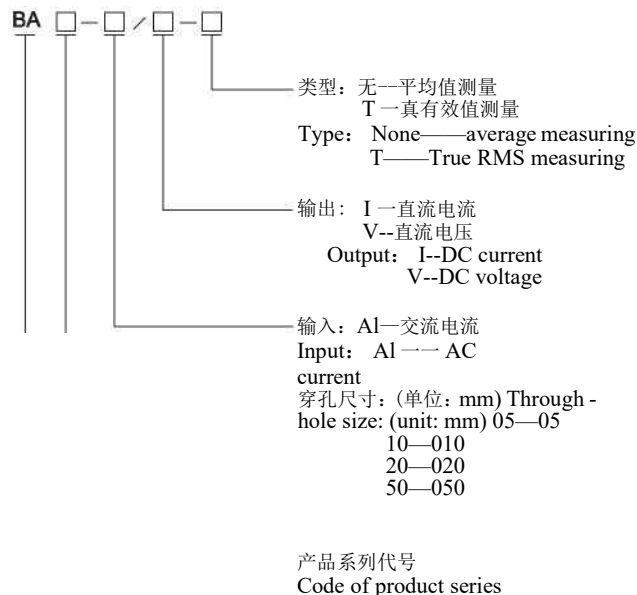

13 通用技术条件 Gemra, specification

电源 Power	电压 Voltage	DC 12V 或 24V DC 12V or 24V
	功耗 Consumption	W1W
绝缘电阻 Insulation resistance		>100MQ
耐压强度 Withstand strength		输入输出、电源之间 2.0kV/1min,50Hz Between input/output, power supply 2.0kV/1min, 50Hz
温度系数 Temperature coefficient		-10P~+55P 时, W200PPM/X;
环境 Environment	温度 Temperature	工作: -10P~+55P, 储存: -25P~+70P Working: -10P~+55P, storage: -25P~+70P
	湿度 Humidity	W95%RH, 不结露, 无腐蚀性气所 <95% RH, No condensation, without corrosive gas
	海拔 Altitude	W 2000m
安装方式 Installation mode		TS35 导轨, 或用螺钉固定柜体上 TS35 guide rail, fix on cubicle with screws

4.1 BA05-AI 交流电流传感器

BA05-AI/I(V) 交流电流传感器 (平均值法测量)
BA05-AI/I(V)-T 交流电流传感器 (真有效值法测量)

4.1 BA05-AI AC current sensor BA05-AI/I(V)
Single phase AC current sensor (average measuring) BA05-AI/I(V)-T Single phase AC current sensor (True RMS measuring)

技术参数 Technical Parameters		指标 Value
精度等级 Accuracy class		0.5 级、0.2 级 0.5 class, 0.2 class
输入 Input	标称值 Nominal value	电流 AC0.5A、5A、10A 等 AC0~(0.5~10)A Current AC 0.5A, 5A, 10A etc. AC 0~(0.5~10)A
	过载 Overload	持续 1.2 倍, 瞬时电流 10 倍/1s Continuous 1.2times, instantaneous current 10 times/1 second
	吸收功率 Absorbed power	W1VA
输出 Output	频响 Frequency response	25Hz~800Hz(平均值), 25~5kHz(真有效值), 特别适合工频场合 25Hz~800Hz(average), 25~5kHz(true RMS), specially suitable for power frequency application
	标称值 Nominal value	DC4~20mA, 或 0~20mA, 0~5V, 0~10V 等 DC4~20mA, or 0~20mA, 0~5V, 0~10V etc.
	负载电阻 load resistance	电流输出时 W500Q, 电压输出时 N1kQ Current output W500Q, Voltage outputs 1 kQ
响应时间 Response time		平均值 W350ms, 真有效值 W 100ms

4.2 BA10-AI 交流电流传感器 BA10-AI/I(V)
交流电流传感器(平均值法
测量)

4.2 BA10-AI AC current sensor
BA10-AI/I(V) Single phase AC current
sensor (average measuring)

BA10-AI/I(V)-T 交流电流传感器(真有效值 法
测量)

BA10-AI/I(V)-T Single phase AC current
sensor (True RMS measuring)

技术#® Technical Parameters		指标 Value
精度等级 Accuracy class		0,5 级、0,2 级 0.5 class、0.2 class
输入 Input	标称值 Nominal value	电流 AC8A、25A、50A 等 AC 0~(8~50)A Current AC 8A、25A、50A etc.AC 0~(8~50)A
	过载 Overload	持续 1.2 倍, 瞬时电流 10 倍/1S Continuous 1.2times, instantaneous current 10 times/1 second
	吸收功率 Absorbed power	W1VA
	频响 Frequency response	25Hz~800Hz(平均值), 25~5kHz(真有效值), 特别适合工频场合 25Hz~800Hz(average), 25~5kHz(true RMS), specially suitable for power frequency application
输出 Output	标称值 Nominal value	DC4~20mA, 或 0~20mA, 0~5V, 0~10V 等 DC4~20mA, or 0~20mA, 0~5V, 0-10V etc.
	负载电阻 load resistance	电流输出时 W500Q, 电压输出时 NikQ Current output W500Q, Voltage output. 1kQ
响应时间 Response time		平均值 W 350ms, 真有效值 W 100ms

4.4 BA50-AI 交流电流传感器 BA50-AI/I(V)
交流电流传感器(平均值法
测量)

4.5 BA50-AI AC current sensor BA50-AI/I(V)
Single phase AC current sensor (average
measuring) BA50-AI/I(V)-T Single phase AC
current sensor (True RMS measuring)

BA50-AI/I(V)-T 交流电流传感器(真有效值 法
测量)

技术#® Technical Parameters		指标 Value
精度等级 Accuracy class		0,5 级、0,2 级 0.5 class、0.2 class
输入 Input	标称值 Nominal value	电流 AC60A、300A、600A 等 AC 0~(60~600)A Current AC 60A, 300A、600A etc.AC 0~(60~600)A
	过载 Overload	持续 1.2 倍, 瞬时电流 10 倍/1S Continuous 1.2times, instantaneous current 10 times/1 second
	吸收功率 Absorbed power	W1VA
	频响 Frequency response	25Hz~800Hz(平均值), 25~5kHz(真有效值), 特别适合工频场合 25Hz~800Hz(average), 25~5kHz(true RMS), specially suitable for power frequency application
输出 Output	标称值 Nominal value	DC4~20mA, 或 0~20mA, 0~5V, 0~10V 等 DC4~20mA, or 0~20mA, 0~5V, 0~10V etc.
	负载电阻 load resistance	电流输出时 M500Q, 电压输出时 RkQ Current output W500Q, Voltage outputs 1kQ
响应时间 Response time		平均值 W 350ms, 真有效值 W 100ms

4.3 BA20-AI 交流电流传感器 BA20-AI/I(V)
交流电流传感器(平均值法
测量)

4.3 BA20-AI AC current sensor BA20-AI/I(V)
Single phase AC current sensor (average
measuring) BA20-AI/I(V)-T Single phase AC
current sensor (True RMS measuring)

BA20-AI/I(V)-T 交流电流传感器(真有效值 法
测量)

技术鉅 Technical Parameters		指标 Value
精度等级 Accuracy class		0,5 级、0 浏 0,5 class、0.2 class
输入 Input	标称值 Nominal value	电流 AC40A、100A、200A 等 AC 0~(40~200)A Current AC 40A _x 100A、200A etc.AC 0~(40~200)A
	过载 Overload	持续 1,2 倍, 瞬时电流 10 倍/1S Continuous 1.2times, instantaneous current 10 times/1 second
	吸收功率 Absorbed power	W1VA
	频响 Frequency response	25Hz~800Hz(平均值), 25~5kHz(真有效值), 特别适合工频场合 25Hz~800Hz(average), 25~5kHz(true RMS), specially suitable for power frequency application
输出 Output	标称值 Nominal value	DC4~20mA,或, ~20mA, 0~5V, 0~10V 等 DC4~20mA or 0~20mA/0~5V 0~10V etc.
	负载电阻 load resistance	电流输出时 W500Q,电压输出时 RkQ Current output W500Q, Voltage output>1kQ
响应时间 Response time		平均值 W 350ms,真有效值 W 100ms

15 外型及安装 | Outline and installation

5.1 BA05-AI 交流电流传感器

5.1 BA05-AI AC current sensor

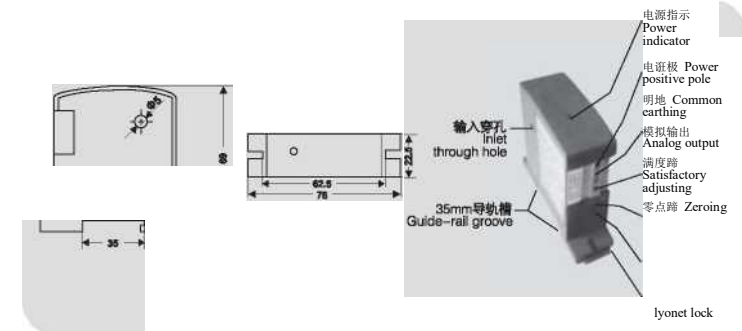

5.2 BA10-AI 交流电流传感器

5.2 BA10-AI AC current sensor

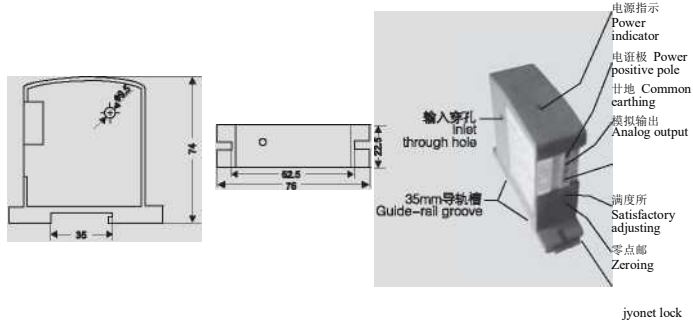

5.3 BA20-AI 交流电流传感器

5.3 BA20-AI AC current sensor

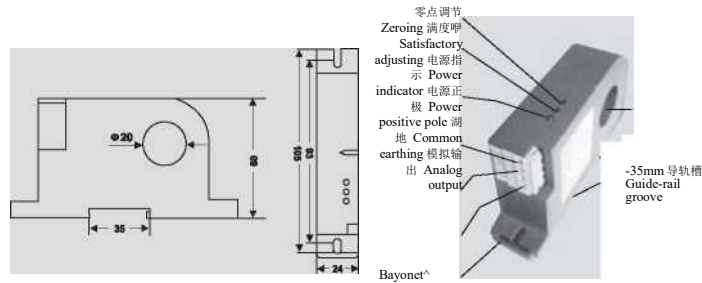

5.4 BA50-AI 交流电流传感器

5.4 BA50-AI AC current sensor

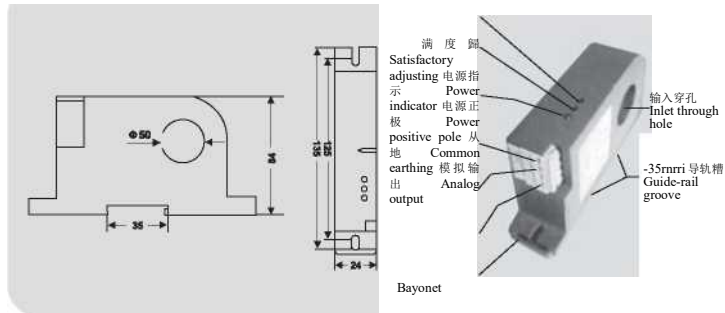

5.5 应用实例

5.5 Applied example

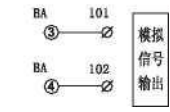
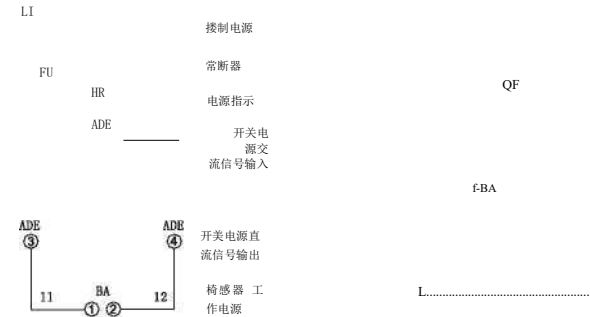

BA	1	101	
BA	2	102	
	3		
	4		
	5		

5	FU	断路器	RT14-20/2A	1
4	ADE	开关电源	ADE03-15 AC220V/24VX3	1
3	HR	信号灯	AD16-22B/31 AC220V	1
2	BA	交流电流传感器 断路器	BA50-AI	1
1	QF			1

合同号	
标记	数量
设计	标准化
制图	审定
校核	批准
工艺	日期

BA50-AI
交流电流传感器



上海安科瑞电气有限公司

【二湖】收礙珀 51 適由冻豺 1 AC residual

6.1 BA50L-AI/I(V)-T 交流剩余电流传感器
(真有效值测量)

6.1 BA50L-AI/I(V)-T AC residual current sensor
(True RMS measuring)

技术指标 Technical Parameters		指标 Value
精度等级 Accuracy class		0.5 级、0.2 级 0.5 class、0.2 class
输入 Input	标称值 Nominal value	电流 AC 0.1 A、1A 等 AC0~(0.1~1)A Current AC 0.1 A、1A etc.AC 0~(0.1~1)A
	过载 Overload	持续 1.2 倍, 瞬时电流 1 漏/1S Continuous 1.2times, instantaneous current 10 times/1 second
	吸收功率 Absorbed power	W1VA
输出 Output	频响 Frequency response	25~5kHz(真有效值), 特别适合工频场合 25~5kHz(true RMS), specially suitable for power frequency application
	标称值 Nominal value	DC4~20mA, 或 0~20mA, 0~5V, 0~10V 等 DC4~20mA, or 0~20mA, 0~5V, 0~10V etc.
响应时间 Response time		真有效值 W 100ms
测量方法 Method measuring		真有效值测量法 True RMS measurement

6.2 BA50L-AI 交流剩余电流传感器外形及安装

6.2 BA50L-AI Outline and installation of AC residual current sensor

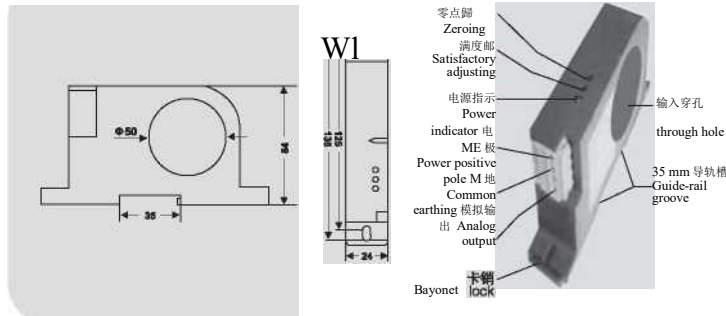

6.3 应用实例

6.3 Applied example

6.3.1 单相回路

6.3.1 Single phase circuit

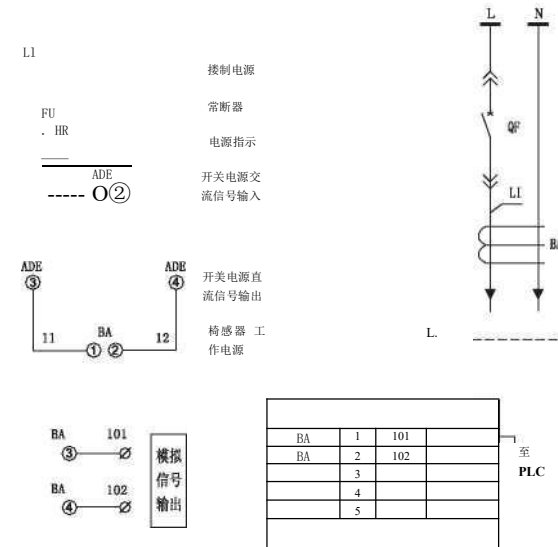

6.2 BA50L-AI 交流剩余电流传感器外形及安装

6.2 BA50L-AI Outline and installation of AC residual current sensor



6.3.2 三相三线回路

6.3.2 Three - phase three - wire circuit

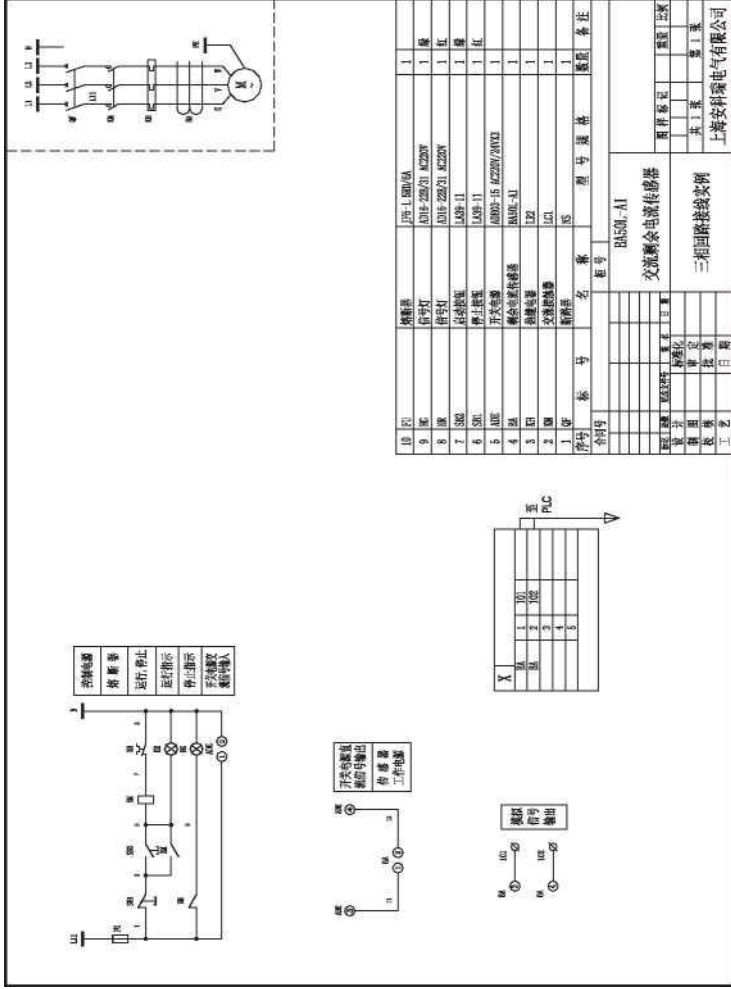

6.3.3 三相四线回路

6.3.3 Three - phase four - wire circuit

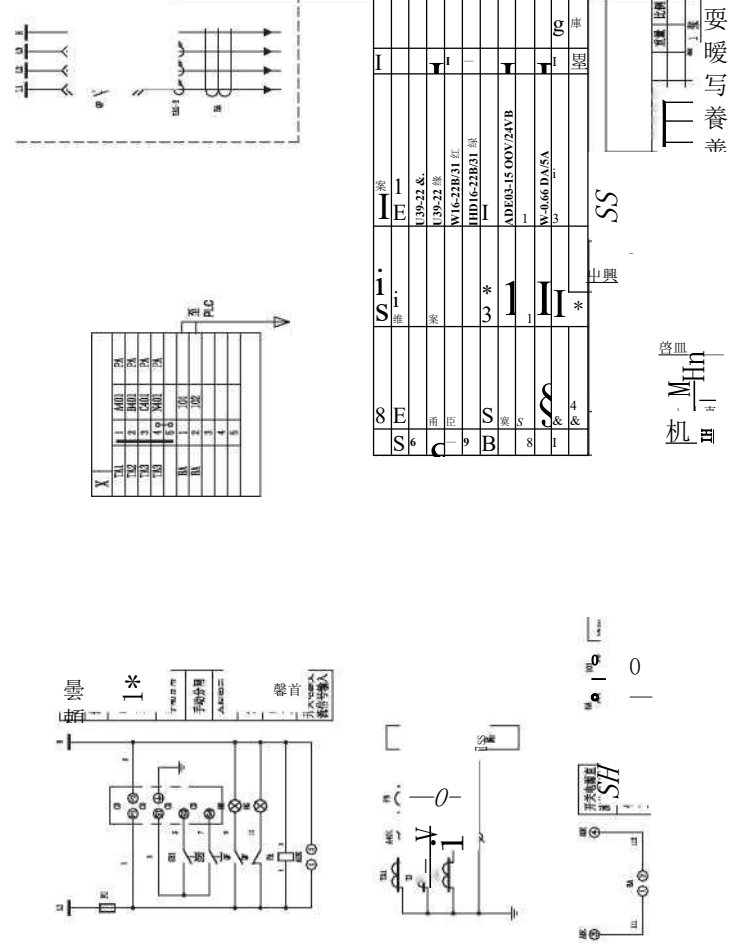

11r 盛峯 *Connection mode*

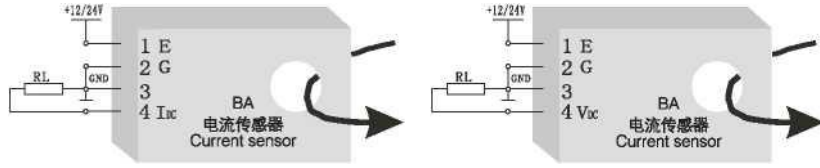

- 1 — E 电源正极（注意电源正极与地不可接反）
 - 2- G 电源地
 - 3- 输出地（可与电源共地，适用于远距离变送）
 - 4- IDC（电流输出正极），VDC（电压输出正极）
- 1 - E power positive pole (inverse connection with earth is forbidden)

- 2- G power earthing
 - 3- Output earthing (can share earthing with the power, applied to long distance transmitting)
 - 4 - IDC (current output positive pole), VDC (voltage output positive pole)
- 辅助电源: DC24V
Auxiliary power supply:

注：具体接线按实物外壳上的接线图为准

Note: The concrete connection as per the wiring diagram on the specific product case shell.

1 陽 1 齒的 *Ordering example*

例 1 BA05-AI/I 平均值交流电流传感器

EXP1 BA05-AI/I Average AC current sensor

辅助电源: DC24V
Auxiliary power supply:

输入: AC5A
Input:

输出: DC4 ~20mA
Output:

精度: 0,5 级
Precision:

例 2 BA05-AI/I - T 真有效值交流电流传感器

EXP2 BA05-AI/I - T True RMS AC current sensor

输入: AC5A
Input:

输出: DC4~20mA
Output:

精度: Q5 级
Precision:

例 3 BA50L—AI/I (V) 交流剩余电流传感器

EXP3 BA50L-AI/I(V) AC residual current sensor

辅助电源: DC24V
Auxiliary power supply:

输入: AC1A
Input:

输出: DC4~20mA
Output:

精度: 0,5 级
Precision: